

# MotorGuide® REPAIR PARTS

**Model:**  
**540**

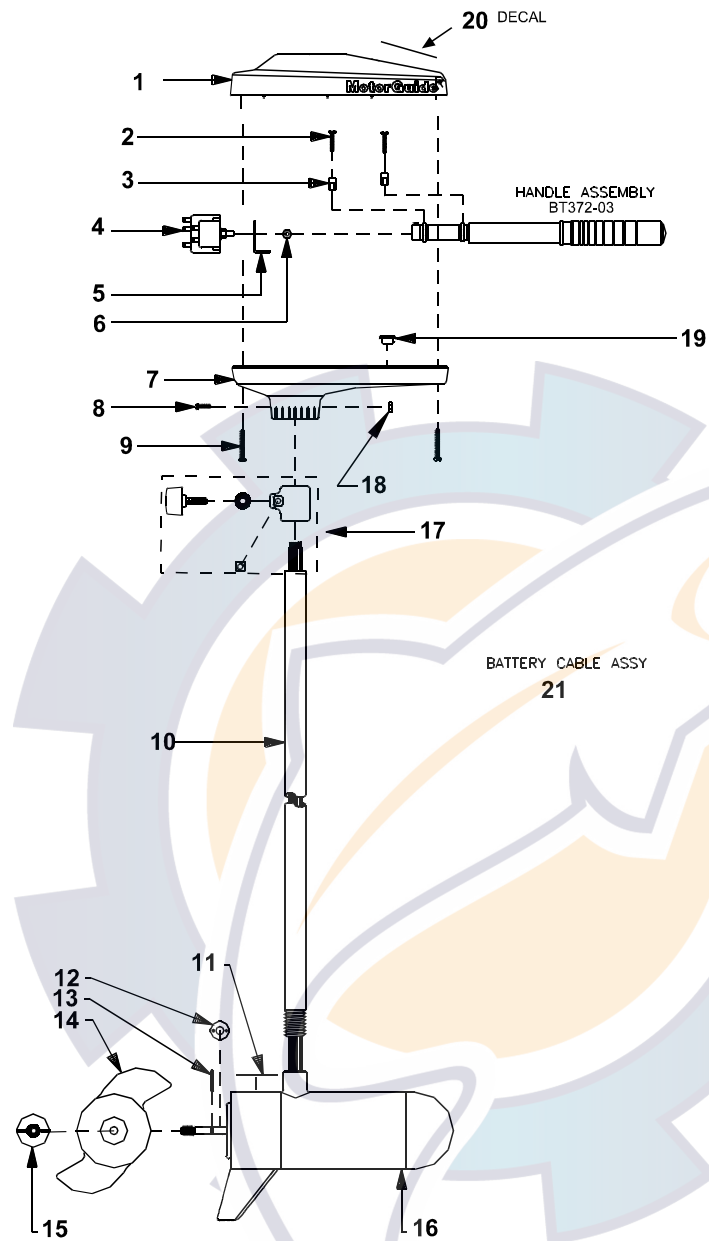

**SPECIFICATIONS:**

Year of Intro	1993
Thrust	35 to 41LBS
Volts	12VDC
Amp Draw	0 to 48 amps
Mount	01 Bow
Speeds	5 For/2 Rev

**QUICK REFERENCE PARTS GUIDE:**

Handle Asy	BT372-03
Motor Seal Kit	6220
Rotary Switch	KT150-02

**PARTS ORDERING & TECH ASSISTANCE**

MotorGuide Consumer Relations  
Phone 918-831-6989  
Fax 800-982-8093

**Send Returned Goods to:**  
MotorGuide  
605 Hwy 12 West  
Starkville, MS 39760

*Returned Goods must be accompanied with a Returned Goods Authorization. Contact MotorGuide Consumer Relations to obtain RGA.*

KEY	DESCRIPTION	PART #
1	COVER WHITE	FR053-10
	COVER BLACK	FR053-11
2	8x1 3/8 SCREW	AR133-01
3	RETAINER CLAMP	AR036-01
4	ROTARY SWITCH	KT150-01
5	BRACKET	AT155-02
6	NUT	AT098-01
7	T/H BASE WHITE	FR004-03
	T/H BASE BLACK	FR004-06
8	1/4X20 HEX HEAD	XT134-02
9	8X 1 3/8 SCREW	AR133-01
10	42" .095 SS H/O COLUMN	FR049-15
11	MARINE LOWER UNIT DECAL	AF060-04
12	MONOFILAMENT WASHER	AR175-01
13	PROP DRIVE PIN	BR102-01
14	PROP/ 2 BLADE	AF124-10
15	PROP NUT	AR099-01
16	MOTOR	DF397-02
17	DEPTH COLLAR ASSY	AR158-01
18	NYLON LOCK NUT	XT098-02
19	GROMMET	GR019-03
20	DECAL	BT056-04
21	BATTERY CABLE ASSY	BT328-03

LOWER UNIT BREAKDOWN

Model:  
**540**

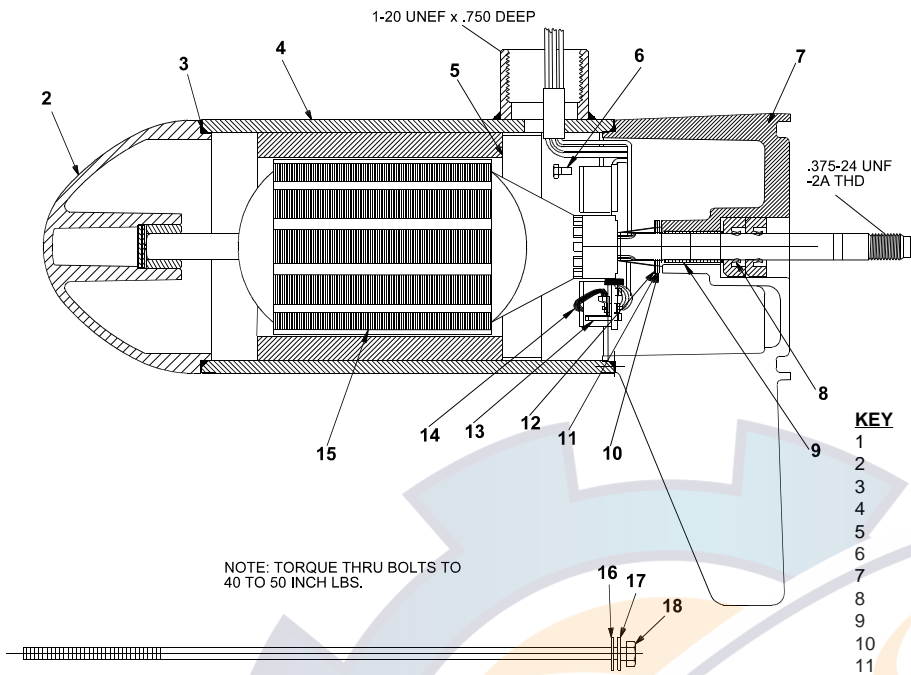

NOTE: TORQUE THRU BOLTS TO 40 TO 50 INCH LBS.

KEY	QTY	DESCRIPTION	PART NO.
1	X	MOTOR	DF397-09
2	1	NOSE CAP	JF3212-01
3	2	O RING SEAL	MR217-01
4	1	HOUSING ASY	JF3210-01
5	1	RETAINER	JF233-01
6	2	BRUSH CARD SCREW	MR228-01
7	1	COMM CAP	DF3205-03
8	2	SHAFT SEAL	MR223-01
9	1	BEARING	MR206-01
10	1	NYLATRON WASHER	MR226-01
11	1	WASHER	MR227-01
12	1	E RING	MR219-01
13	2	BRUSH SPRINGS	MR214-02
14	1	BRUSH ASY LESS SPRING	DF3201-02
15	1	ARMATURE 3.5"	CF3207-01
16	4	STATIC SEAL	MR222-01
17	4	THRU BOLT WASHER	MR216-01
18	2	THRU BOLT	MR218-02

WIRING

